

SPECIFICATIONS

1. THIS SPECIFICATIONS APPLY TO RK11K1140 POTENTIOMETERS.

2. CONTENTS OF THIS SPECIFICATIONS.

F3853159M
K111H0Z21

3. MARKING

· MARKING ON ALL UNITS
DATE CODE, RESIST. VALUE, TAPER

4. REMARKS

· FURNISH PACKAGE
NUT: 1, WASHER: 1
· NOTES

· This unit uses polycarbonate. To be careful for using this unit in such violent gas atmospheric condition as ammonia, amine, alkaline aqueous solution, aromatic hydrocarbon, keton, ester, alkyl hydrocarbon, etc.

SPECIFICATIONS

ELECTRICAL

1. Total resistance : 50 k Ω \pm 20%
2. Rated power : 0.05 W
3. Rated voltage :

The rated voltage shall be the voltage of D.C. or A.C. (commercial frequency, effective value) corresponding to the rated power (dissipation), and be obtained from the following formula. When the obtained rated voltage exceeds the maximum working voltage given in the following, however, the maximum working voltage of the following shall be the rated voltage.

$$E = \sqrt{P \cdot R} \text{ (V)}$$

Where
 E : Rated voltage (V)
 P : Rated power (dissipation) (W)
 R : Nominal total resistance (Ω)

Maximum working voltage : 50 V A.C. , 20 V D.C.

4. Resistance taper : A
5. Residual resistance between term. 1&2, 2&3 : 0.1% max. of nominal total resistance

6. Sliding noise : Less than 100 mV. (Measured by JIS C 6443)

7. Insulation resistance : More than 100 M Ω at 500V D.C.
8. Withstand voltage: 500V A.C. for one minute.

MECHANICAL

1. Total rotational angle : 300° \pm 5°
2. Rotational torque : 30~200 gf·cm (Rotational speed 60°/sec.)
3. Resistance to soldering heat :
 After soldering (Less than 300°C and within 3 seconds) there shall be no evidence of poor contact between resistance element and terminals, or any physical damages as a result of the test.
4. Stopper strength : 6 kgf·cm min. (figures at break)
5. Robustness after soldering resistor shaft against end thrust and pull force :
 After installing the potentiometer, the shaft shall withstand against end thrust and pull force of more than 8 kgf.
6. Robustness at shaft against side thrust :
 After installing the potentiometer, the shaft shall withstand against side thrust of more less than 3 kgf on the end of the shaft at right angles to the axis of the shaft.
7. Shaft play :
 After installing the potentiometer, the resistor shall be mounted by soldering the mounting legs on the panel. When a side thrust of 500 gf·cm shall be applied at the end of the shaft, the total shaft play shall not exceed 0.7XL/30 mm p-d. (L: Shaft length)
8. Bushing nut tightening strength : Tightening torque to be no greater than 10 Kgf·cm
 Pay attention otherwise the strength may not be assured.

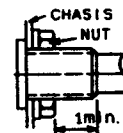

ENDURANCE

1. Rotational life : 15,000 cycles min.

NOTE

1. The items except above mentioned items shall meet or exceed JIS C 6443.

ALPS ELECTRIC CO., LTD.				
	APPD.	CHKD.	DSGD.	TITLE
	Oct. 01. '92	Oct. 01. '92	Oct. 01. '92	F 3853159M
	S. Aizawa	M. Satoh	S. Sugawara	DOCUMENT NO.
SYMB	DATE	APPD	CHKD	DSGD



ALPS ELECTRIC CO., LTD
1-7 YUKIGAYA OTSUKA-CHO OTA-KU TOKYO JAPAN

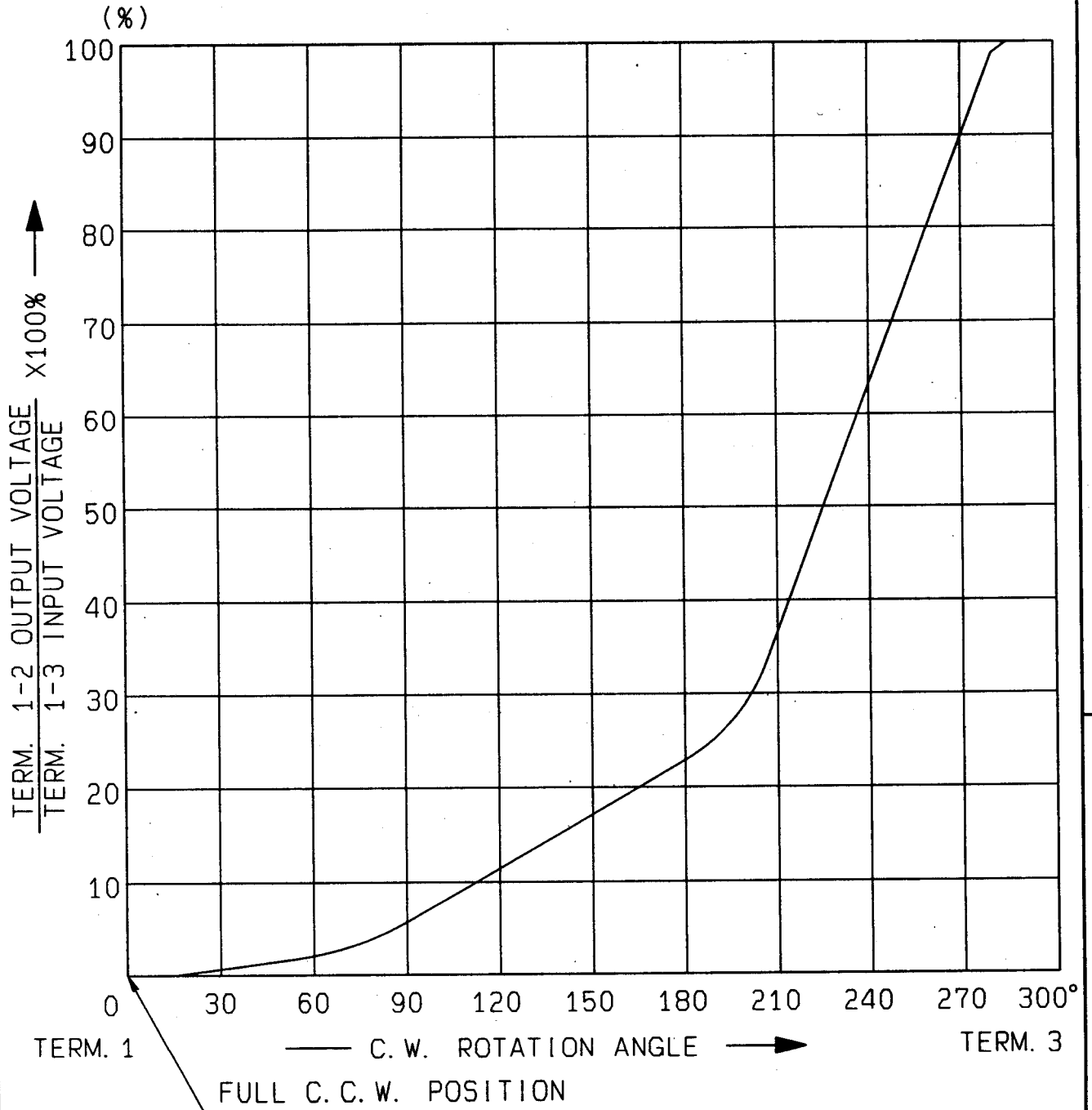

AT 150° C.W. SHAFT ROTATION FROM FULL C.C.W. POSITION VOLTAGE PERCENT SHALL FALL WITHIN THE LIMITS OF 10~25 PERCENT.

					APPD.	CHKD.	DSGD.	NAME	A
					may. 27. '92		may. 27. '92	RESISTANCE TAPER	
					M. Inoue		S. Sasaki	DOCUMENT NO.	
SYMB	DATE	APPD	CHKD	DSGD				F3853159M	

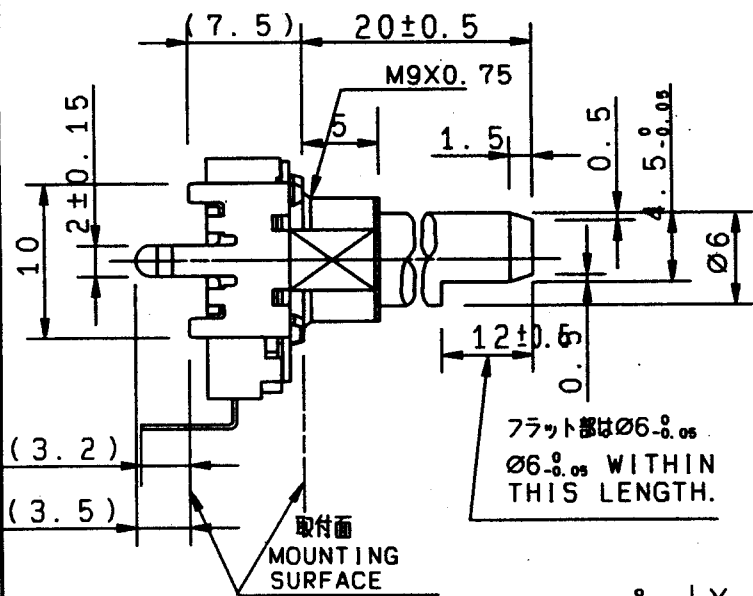

フラット部は $\phi 6_{-0.05}^{+0.05}$
 $\phi 6_{-0.05}^{+0.05}$ WITHIN
 THIS LENGTH.

取付穴寸法図(公差 ± 0.1)
 *挿入側からみた図
 P. W. B. MOUNTING DETAIL
 (TOLERANCE ± 0.1)
 VIEWED FROM MOUNTING SIDE

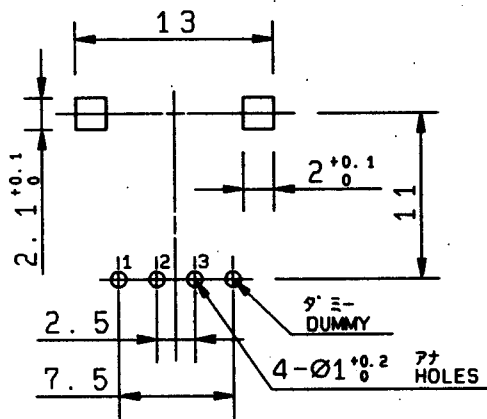

P. W. B. 板厚 T=1.6

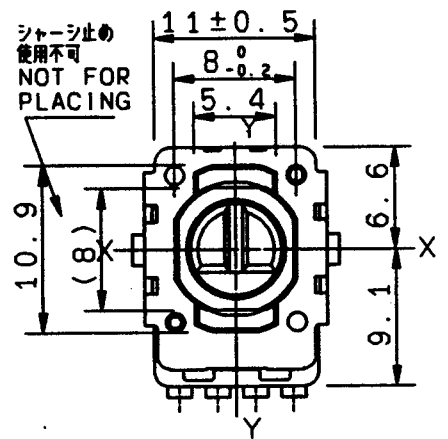

シャフト止の
 使用不可
 NOT FOR
 PLACING

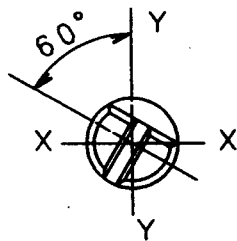
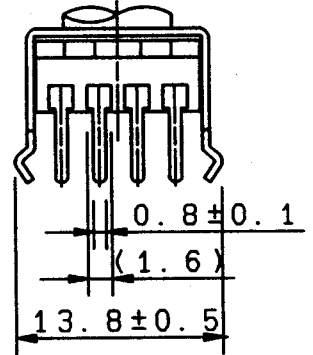

軸は反時計方向に
 回しまった状態を示す
 SHAFT SHOWN
 IN FULL C. C. W.
 POSITION.

軸はセンター位置又は
 センタークリック位置を示す
 SHAFT SHOWN IN
 CENTER POSITION
 OR CENTER CLICK
 POSITION.

指定なき部分の許容差 TOLERANCES UNLESS OTHERWISE SPEC	
$L \leq 10$	± 0.3
$10 < L < 100$	± 0.5
$100 \leq L$	± 0.8
角度 ANGULAR DIMENSION	$\pm 5^\circ$

PART NO.	NAME	MATERIAL NAME / CODE	FINISH
ALPS ALPS ELECTRIC CO., LTD.			
	DSGD. 1-設計1員	SCALE	
	Y. SAITOH '94-07-20	2 : 1	F3853159M
	CHKD.	TITLE	FIGURE
	M. SATOH '94-07-20		11形単速絶縁軸ポリウム組立図
	APPD.	UNIT	DOCUMENT NO.
	R. ARASAWA '94-07-20	mm mm	K111HOZ21
SYMB	DATE	APPD	CHKD
			DSGD

FX1

F03